

# L.E.O. Satellite Power Subsystem Reliability Analysis

M. Zahran<sup>†\*</sup>, S. Tawfik<sup>\*</sup> and Gennady Dyakov<sup>\*</sup>

<sup>†</sup>Electronics Research Institute, NRC Bldg., El-Tahrir St., Dokki, 12311-Giza, EGYPT

<sup>\*</sup>National Authority for Remote Sensing and Space Science, Cairo Egypt

<sup>\*\*</sup>Yuzhnoye State Design Office, 3, Kryvorozhskaya st., Dnipropetrovsk, Ukraine

## ABSTRACT

Satellites have provided the impetus for the orderly development of reliability engineering research and analysis because they tend to have complex systems and hence acute problems. They were instrumental in developing mathematical models for reliability, as well as design techniques to permit quantitative specification, prediction and measurement of reliability. Reliability engineering is based on implementing measures which insure an item will perform its mission successfully. The discipline of reliability engineering consists of two fundamental aspects; (1<sup>st</sup>) paying attention to details, and (2<sup>nd</sup>) handling uncertainties. This paper uses some of the basic concepts, formulas and examples of reliability theory in application.

This paper emphasizes the practical reliability analysis of a Low Earth Orbit (LEO) Micro-satellite power subsystem. Approaches for specifying and allocating the reliability of each element of the power system so as to meet the overall power system reliability requirements, as well as to give detailed modeling and predicting of equipment/system reliability are introduced. The results are handled and analyzed to form the final reliability results for the satellite power system. The results show that the Electric Power Subsystem (EPS) reliability meets the requirements with quad microcontrollers (MC), two boards working as main and cold redundant while each board contains two MCs in a hot redundant.

**Keywords:** Reliability analysis, allocation, prediction, Micro-satellite Power Subsystems, EPS configuration, PPT, DET, system effectiveness

## 1. Introduction

The EPS is one of the most critical systems on any satellite because nearly every other subsystem requires power. This makes the choice of power systems the most important task facing satellite designers. The main purpose of the Satellite EPS is to provide continuous, regulated and

conditioned power to all the satellite subsystems within the specified operation period and during ground testing<sup>[1]</sup>.

The optimum choice of EPS components is not usually an easy task for satellite designers due to the closed interaction between the EPS and the dedicated mission of the satellite. The designers must be aware of the various power subsystems available for use on the satellite.

The satellite under study is an Earth Remote Sensing Microsatellite, Sun synchronous orbit with a planned five year lifetime. The most suitable primary source for the proposed satellite is photovoltaic (solar arrays). An energy storage device is needed to power the onboard loads

---

Manuscript received March 6, 2005; revised January 28, 2006

<sup>†</sup>Corresponding Author: Zahran@eri.sci.eg

Tel: 0202-331-0512, Fax: 0202-335-1631, ERI, NARSS

<sup>\*</sup>National Authority for Remote Sensing & Space Science(NARSS)

<sup>\*\*</sup>Yuzhnoye State Design Office

during an eclipse. Also a power and management device is added as a system controller [2].

The electrical power generated at the solar arrays (SA) must be controlled to prevent the storage battery (SB) from overcharging and creating undesired spacecraft heating. Wertz, J. and Larson<sup>[3]</sup>, U. Orlu1, et al.<sup>[4]</sup> and Masoum, Mohamed<sup>[5]</sup> have reported that the two main power subsystem configurations are a peak -power tracker (PPT) and a direct-energy-transfer (DET). A PPT is a non-dissipative subsystem and its disadvantages appear at End Of Lifetime (EOL). An SA and/or SB has sensible values of degradation, while the DET is a dissipative subsystem since its shunt regulator operates in parallel with the solar array to dissipate power if the loads do not require it. The advantages of DET are as follows: fewer parts, lower mass and higher total efficiency at EOL.

## 2. Proposed Microsatellite EPS Configuration

Because of reliability problems in the PPT (PPT is a series device inserted between the main source of energy, the storage battery and the satellite onboard equipment) as well as lower efficiency at EOL, a DET configuration is proposed to be used in the satellite EPS under study.

In this paper the EPS based on DET unregulated bus voltage reliability will be studied. The proposed EPS block diagram is shown in Fig. 1.

The composed of three stages; the solar arrays with its power regulation stage, the management and control stage and the storage subsystem stage. The regulated bus voltage can be classified for different satellites missions as follows: typically 28 V on scientific satellites and 50 V, 70 V or 100 V on large communication satellites<sup>[6,7]</sup>.

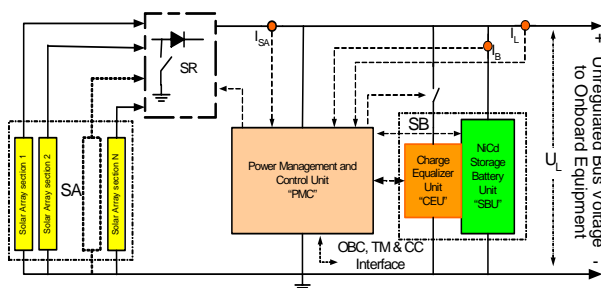

Fig. 1 Block diagram of the proposed Micro-satellite EPS (OBC stands for On-Board Computer, TM stands for Telemetry, and CC stands for Control Commands)

## 3. Satellite EPS Reliability Calculations and Analysis

Based on the satellite EPS DET configuration, the reliability calculations and analysis can be introduced in the following steps:

### 3.1 Reliability Specification:

The essential elements of a reliability specification are:

- A quantitative statement of the reliability requirement specified by the customer as a MINIMUM acceptable value.
- Environment of the power subsystem operation
- Mission lifetime in orbit and ground operation identification
- Constituted failure definition that should be expressed in terms which will be measurable during the demonstration test.

These elements were applied to the current system under the following conditions:

- The Satellite Power System (EPS) under study shall provide operation within 5 years of satellite active lifetime. The reliability of the EPS, within 5 years, shall be not less than 0.97.
- The EPS shall operate as specified under the following environments; 670 km altitude, ~98o inclination and AM0, temperature ~ (-80: +80 oC).
- The Satellite Power System (EPS) under study shall provide continuous operation within 5 years of satellite active lifetime so there is no need to define the time profiles.
- The EPS in a DET configuration has three main subsystems, which are a solar arrays (SA) subsystem, a storage battery (SB) subsystem “which may contain specific type of batteries” and a power management and control (PMC) “subsystem” which may contain a microcontroller with microelectronic circuits to provide controllability or supervision of the EPS.

The key factors affecting EPS functioning efficiency (besides random effects which may lead to EPS subsystems failures) should be considered as:

- Illumination of orbit, illumination and temperature of solar arrays.
- Degradation of SA characteristics from space factor effects.
- Degradation of battery characteristics in the course of its cycling.

**3.2 EPS Reliability Allocation**

Since the required EPS reliability is 97%, then the subsystem EOL failure rate will be:

$$\lambda_{EPS} = -\ln(0.97)/(43830 \text{ hr}) = 6.9494 \cdot 10^{-7}$$

The Feasibility-Of-Objectives Technique is used to allocate the EPS reliability. The EPS reliability allocation of each subsystem can be allocated with the following steps and the illustrated in Table 1:

1. System Intricacy:
  - 1.1. A SA which consists of 8 parallel solar sections will have an intricacy factor of 6,
  - 1.2. SB 22 cells with their CEU has an intricacy factor of 8, and
  - 1.3. A PMC will have an intricacy factor of 10.
2. State-of-the-Art: the three subsystems will have the factors of 3.
3. Performance Time: for the SA it will have the factors of 5 because it will now work throughout the satellite lifetime, but for the SB and PMC it will have factor of 10.
4. Environment: the SA will have a factor of 10 and factors of 5 for both the SB and PMC.
5. Compute the product of the factors for each subsystem

$$W_k^* = r_{1k}^* \cdot r_{2k}^* \cdot r_{3k}^* \cdot r_{4k}^* \quad \text{and their summation}$$

$$W^* = \sum_{k=1}^N W_k^*$$

6. Compute the complexity factors for each subsystem,

$$C_k^* = \frac{W_k^*}{W^*}$$

7. Compute the allocated blocks failure rates,

$$\bar{\lambda}_k = C_k^* \cdot \lambda_{EPS}$$

8. Compute the blocks reliability requirements,

$$R = e^{-\lambda t}$$

Table 1 EPS Allocated Reliability

Subsystem	r <sub>1k</sub> <sup>*</sup> (1)Intricity	r <sub>2k</sub> <sup>*</sup> (2)State-of-the-Art	r <sub>3k</sub> <sup>*</sup> (3) Performance Time	r <sub>4k</sub> <sup>*</sup> (4)Environment	(5)Overallrating	(6)Complexity	(7)Allocated Failure Rate* 10 <sup>-6</sup>	(8)Subsystem Rel. at t=5 years %
					W <sub>k</sub> <sup>*</sup>	C <sub>k</sub> <sup>*</sup>	$\bar{\lambda}_k$	R = e <sup>-λt</sup>
SA	06	03	05	10	0900	0.250	0.1737	99.241
SB	08	03	10	05	1200	0.3333	0.2315	98.989
PMC	10	03	10	05	1500	0.4167	0.2896	98.739
Total					W <sup>*</sup> = 3600	1.0000	0.6948	97.00

The allocation process will stop at this level because the lower level contains parallel and voting configurations. Allocation methods are not suitable for those configurations.

**3.3 EPS Reliability Block Diagrams**

The reliability block diagram is drawn so that each element or function employed in the item can be identified. Each block of the reliability block diagram represents one element of function contained in the item. The blocks in the diagram follow a logical order, which relate to the sequence of events during the prescribed operation of the item [8, 9]. The EPS reliability block diagram is shown and described as:

For SA subsystem operational requirements, the EPS failure definition and environmental conditions selected required 7 SA sections with 1 auxiliary section. Hence, the SA subsystem will contain 8 SA sections (SAS) with condition that failure of one SA section does not lead to a system failure. Each SA section contains three series blocks which are the SA module (SAM), isolating diode (ID) [consists of a diode matrix, which is used in isolating SA faults, blocking the SA in shadow periods and system short circuit protection with a SA module shunting in case of exceeding power exciting] and a shunt regulator (SR) [consists of a transistor matrix with a protection fuse, which used to shunt the exceeding SA power].

The SB subsystem used NiCd batteries with 22 cells connected in series to maintain the bus voltage in an acceptable range under the condition that failure of one section does not lead to a system failure. Each section (BS) will have one battery cell (BC) connected in parallel with a charge equalizing unit (CEU) to avoid the charging and discharging degradation fault of the battery cell.

For PMC, a microcontroller module (MCM) which consists of two parallel microcontroller circuits (MCC) work as a standby redundancy and supervisory module (SM). The SM consists of three supervisory circuits (SC) connected in a voting configuration by “2 of 3” to supervise the microcontroller module operations.

From the subsystem specifications, failure modes and functional diagram a subsystem reliability block diagram was generated as . The “2/8”, “2/22” and “2/3” means that one element failure is acceptable but two element failures lead to a subsystem failure (voting configuration).

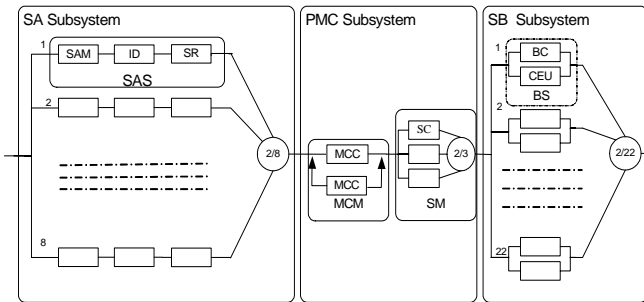

Fig. 2 EPS functional block diagram

### 3.4 EPS Reliability Modeling and Prediction Based on Conventional Technique

First, a Conventional Probability Modeling Method is used to determine the mathematical model EPS. The EPS reliability equation can be formed as follows:

$$R_{EPS} = R_{SA} \cdot R_{SB} \cdot R_{PMC} \quad (1)$$

The reliability equation could also be expressed as shown in the following sections:

#### 3.4.1 Reliability Modeling SA Subsystem

The SA sections (SA) which are connected in a voting configuration “2/8”<sup>[2]</sup>, will have a reliability equation of:

$$R_{SA} = \sum_{i=m}^n \frac{n!}{i!*(n-i)!} \cdot R_{SAS}^i \cdot (1-R_{SAS})^{n-i}, \quad (2)$$

Where:

“n” is the total number of the SA sections which equals 8,

“m = n - k”,

“k” is the number of redundant SA sections which equals 1

From the analysis of possible sudden failures of such sections, the following failures lead to a complete failure of each section:

- Open circuit fault in the isolating diode.
- Short circuit or open circuit faults of a SA section (degradation fault).
- Short circuit fault in the shunt regulator.

In this design, because power is a critical parameter, a fault tolerance procedure was implemented by using shunt regulators with a protective series connected fuse which has the main function of neglecting the effect (isolate) of a short circuit fault in the shunt regulator in case of isolating diode short circuit failure. The only drawback of this action is losing the shunting facility for this SA section which will be handled in the control algorithm that is stored on the microcontroller.

In the solar array module mathematical model there is a series diode, which will work to prevent the consequences of isolating a diode short circuit fault for system failure because the satellite bus voltage range will not be able to breakdown the series diodes of the SA modules, which will not convert the solar array modules to dummy loads.

The open circuit failure of the shunt regulator is neglected because it will only lead to losing the shunting facility for the SA section which will be taken into consideration in the control algorithm that is stored on the microcontroller.

From the previous failure modes and the functional diagram of the SA sections (SAS) a reliability equation of each SA section can be generated as:

$$R_{SAS} = R_{SAM} \cdot R_{ID}^* \cdot [1 - ((1 - R_{SR}^{\oplus}) \cdot R_{ID}^{\oplus})], \quad (3)$$

Where:

$R_{SAM}$  is the probability of a non failure operation

(degradation) of the solar array module,

$R_{ID}^*$  is the probability of a non failure operation for the open circuit isolating diode,

$R_{SR}^\oplus$  is the probability of a non failure operation for the short circuit shunt regulator,

$R_{ID}^\oplus$  is the probability of a non failure operation for the short circuit isolating diode.

### **SB Subsystem**

The battery cells which are connected in a voting configuration “2/22” reliability equation is:

$$R_{SB} = \sum_{j=mb}^{nb} \frac{nb!}{j!*(nb-j)!} \cdot R_{BC}^j \cdot (1-R_{BC})^{nb-j}, \quad (4)$$

Where:

nb is the total number of battery sections which equal 22,

mb = nb - kb”,

“kb” is the number of redundant battery sections which equal 1.

From an analysis of possible sudden failures of such sections, the following failures generated lead to a complete failure of each section:

- Random failure of battery cell (short current).
- Degradation failure of battery cell and simultaneous failure of CEU.

Failures in the nickel cadmium cells of ‘break’ type are not considered since they are classified as impossible according to [ECSS-E-20]. From the previous failure modes and the functional diagram [Fig. 2] of the battery subsystem we can generate the reliability equation of each battery cell can be expressed as:

$$R_{BS} = R_{BC}^\oplus \cdot [1 - ((1 - R_{BC}) \cdot (1 - R_{CEU}))], \quad (5)$$

Where:

$R_{BC}^\oplus$  Probability of a non failure operation of short circuit type for battery cell,

$R_{BC}$  Probability of a non failure operation (degradation) of the battery cell, and

$R_{CEU}$  Probability of a non failure operation

(degradation) of the CEU.

### **PMC Subsystem**

By analyzing the consequences of the control subsystem functional element failures, it is found conclusively that a failure of the PMC subsystem occurs only if both MCM and SM units fail. The reliability equation for the PMC is:

$$R_{PMC} = R_{MCM} \cdot R_{SM}, \quad (6)$$

Where:

$$R_{MCM} = R_{MCC} \cdot (1 - \ln(R_{MCC})), \quad (7)$$

$$R_{SM} = \sum_{k=ms}^{ns} \frac{ns!}{k!*(ns-k)!} \cdot R_{SC}^k \cdot (1 - R_{SC})^{ns-k}, \quad (8)$$

“ns is the total number of supervisory subsystem circuits which equals 3, and “ms = ns - ks”,

“ks” is the number of redundant supervisory subsystem circuits (equals 1).

### **3.4.2 Reliability Prediction**

Predictions are a means of determining the feasibility of requirements and of assessing progress towards achieving those requirements. In general, there is a hierarchy of reliability prediction techniques available to the designer. This technique is well described in the MIL-HDBK-217 series [10-19].

In this paper, a brief example is shown to present the prediction analysis which has been applied to the system devices and components. This example is the MCC block which consists of the following devices which are from detailed design function block diagrams (assumed as a complex setup or worst case): - Microcontroller “MC”, - Digital to Analog Converter “ADC”, - Linear Operational Amplifiers “LOA” (10 units), - Opto-Couplers “OC” (40 units), - BJT Transistors “BT” (40 units), - Zener Diodes “ZD” (5 units), - General Purpose Diodes “GPD” (5 units), - Power Diodes “PD” (3 units), - Capacitors “C” (50 units), - Resistors “R” (70 units), - Connectors “CON” (25 units), - Relays “REL” (10 units) and, - Circuit Boards two layers “CBO” (2 units). As an example of determining the operating and non-operating failure rates for each device, an MC is used in this paper. The MC is produced by

ATMEL Corp., which is based on AVR technology. The MC operating failure rate; results are shown in Table 2:

Table 2 MC operating failure rate calculation steps

Nr	Parameter	Value	Reason or Source
1	The quality factor for the MC $\pi_Q$	1	From MIL-HDBK-217 quality factors tables for screening level class B (also provided by ATMEL),
2	Learning factor $\pi_L$	1	Because ATMEL stayed in it production more than 2 years
3	Environment factor $\pi_E$	12	MIL-HDBK-217 environment factors tables in case of M <sub>L</sub> class,
4	Voltage acceleration factor $\pi_V$	1	Because the MC is a CMOS device and it supply voltage not more than 12 volt
5	Packaging factor C <sub>2</sub> [20]: $C_2 = 3.6 \cdot 10^{-4} \cdot (64)^{1.08} = 0.03213$	0.0321	MC in package with 64 pins,
6	Die complexity factor C <sub>2</sub>	0.02	MIL-HDBK-217 complexity factors tables in case of digital microelectronics, Note 1,
7	Temperature acceleration factor $\pi_T$	0.3193	Note 2

Note 1: The summarized complexity factors for the linear and digital integrated microelectronics are shown in Table 3.

Table 3 linear and the digital integrated microelectronics complexity factor

Digital		Linear	
No. of Gates	C <sub>1</sub>	No. of Transistors	C <sub>1</sub>
1 to 100	0.0025	1 to 100	0.01
101 to 1,000	0.005	101 to 300	0.02
1,001 to 3,000	0.01	301 to 1,000	0.04
3,001 to 10,000	0.02	1,001 to 10,000	0.06
10,001 to 30,000	0.04		
30,000 to 60,000	0.08		

Note 2: The temperature acceleration factor  $\pi_T$  is calculated as:  
 - the maximum was employed. Power dissipation “P” from the MC Datasheets which equals 400 mW, - the junction for case thermal resistance  $\theta_{jc} = 10 \text{ }^\circ\text{C} / \text{W}$ , - the MC maximum case temperature was determined as “TC” from the design data, environmental data and the MC Datasheets to be equal 45 C, - we calculated the MC

junction temperature was calculated as:  
 $T_j = 45 + 10 \cdot (0.4) = 49 \text{ }^\circ\text{C}$ , Then, the temperature acceleration factor is calculated as:

$$\pi_T = 0.1 \cdot \exp \left[ -4642 \cdot \left( \frac{1}{49 + 273} - \frac{1}{298} \right) \right] = 0.3193$$

Finally, the MC operating failure rate was calculated as:

$$\lambda_{MC} = 1 \cdot (0.02 \cdot 0.3193 \cdot 1 + 0.03213 \cdot 12) \cdot 1 = 0.3920 \text{ failures per } 10^6 \text{ hours}$$

The MC non-operating failure rate equals 0 because the MC will operate continuously during the satellite lifetime. After the MC failure rate prediction analysis, a failure rate is expected for all the MCC blocks and the results are shown in table 4.

Table 4 MCC blocks failure rates

Device	Predicted failure rate / 10 <sup>6</sup> Hrs.	Quantity used	Total failure rate/ 10 <sup>6</sup> Hrs.
MC	0.3920	1	0.3920
DAC	0.1	1	0.1
LOA	0.1	10	1
OC	0.007	40	0.28
BT	0.01	40	0.4
ZD	0.02	5	0.1
GPD	0.05	3	0.15
PD	0.01	3	0.03
C	0.002	50	0.1
R	0.001	70	0.07
CON	0.001	25	0.025
REL	0.002	10	0.02
CBO	0.016	2	0.032
Total (MCC)			2.699

From Table 4 we calculated the MCC predicted reliability value after 5 years as:

$$R_{MCC} = e^{-2.699 \cdot 10^{-6} \cdot 43830} = 0.8884.$$

The predicted reliability values for the system blocks were calculated in the same way and the results are shown in Table 5.

Table 5 EPS blocks predicted reliability values

Block		Reliability (probability of non failure)
SAM		0.9900
ID	-For Open Circuit	0.9950
	-For Short Circuit	0.9800
SR	-For Short Circuit	0.9950
CELL	- For degradation	0.9800
	-For Short Circuit	0.9950
CLU		0.9700
MCC		0.8884
SC		0.9700

From the predicted reliability values for the system blocks, we go throw for remodeling the EPS reliability using the conventional method. From observations of the reliability modeling, subsection 0, system reliability is implemented as shown in following steps:

1. 
$$R_{SAS} = 0.99 \cdot 0.995 \cdot [1 - ((1 - 0.995) \cdot 0.98)]$$

$$= 0.98$$
2. 
$$R_{SA} = \sum_{i=7}^8 \frac{8!}{i! \cdot (8-i)!} \cdot R_{SAS}^i \cdot (1 - R_{SAS})^{8-i}$$

$$= 0.989883$$
3. 
$$R_{BC} = 0.995 \cdot [1 - ((1 - 0.98) \cdot (1 - 0.97))]$$

$$= 0.9944$$
4. 
$$R_{SB} = \sum_{j=21}^{22} \frac{22!}{j! \cdot (22-j)!} \cdot R_{BC}^j \cdot (1 - R_{BC})^{22-j}$$

$$= 0.99328$$
5. 
$$R_{MCM} = 0.8884 \cdot (1 - \ln(0.8884))$$

$$= 0.9935$$
6. 
$$R_{SM} = \sum_{k=2}^3 \frac{3!}{k! \cdot (3-k)!} \cdot R_{SC}^k \cdot (1 - R_{SC})^{3-k}$$

$$= 0.997354$$
7. 
$$R_{PMC} = R_{MCM} \cdot R_{SM} = 0.9935 \cdot 0.997354$$

$$= 0.9909$$

Applying equation 1, the EPS final reliability can be calculated as:

$$R_{SPS} = 0.989883 \cdot 0.99328 \cdot 0.9909$$

$$= 0.974286$$

The final result shows that the EPS at EOL meets the requirements; 97%.

#### 4. EPS Operational Effectiveness

The Monte Carlo simulation<sup>[21]</sup> is used in this paper as one of the fault tree analysis tasks. The fault tree analysis in this paper involves both qualitative and quantitative techniques<sup>[8, 22, 23]</sup>. The qualitative technique provides information on the system operational effectiveness function over time (using Monte Carlo simulation). The quantitative technique provides information on the system minimal cut sets, the nature of the basic events (block failures) and the number of basic events in the combined sets. This in turn gives important information about the top event occurrence, the occurrence probability of the top event (system failure probability) and also the dominant cut sets that contribute to the top event probability. The quantitative importance of each basic event contributing to the top event is also shown. Minimal cut sets in this case are sorted by probability. Low probability minimal cut sets are truncated from this analysis. Our program involves the following steps:

1. For 100,000 times (trials), the program completed the following: Generating random failure times for every block in the system using an exponential distribution function, which is based on the block predicted failure rate, and calculating the system operational effectiveness over the satellite life time (Monte Carlo simulation).
2. Calculating the system average operational effectiveness (for 100,000 trials) over the satellite lifetime.
3. Computing the failures that lead to the top event and identifying system minimal cut sets.
4. Calculating at certain times the occurrence probability of each minimal cut set which uses the system blocks reliability values.
5. Calculating the top event occurrence probability and then the system reliability at certain times.
6. Calculating the contribution of each minimal cut set and system blocks to system failure and generating the program results report.

This conventional method calculated the system reliability in the worst case where the SM is connected in series with the MCM. In the actual case, SM failure does not lead to PMC failure and complete system failure. For the series connection of the SM and MCM the consequences of a SM failure will appear when using the weighted reliability technique by giving the SM a weighting coefficient that is less than 1 to reflect the consequence of its failure to the system failure. The only drawback of this technique is accurately determining the SM weighting coefficient. Using Monte Carlo simulation with the various SM weighting coefficients will help determine the correct value of the SM weighting coefficient, estimate the system operational effectiveness over the satellite lifetime and the non-failure probability of the system (system reliability). System failure occurs when the system operational effectiveness is less than a certain threshold value.

Weighting coefficients for some system elements were used to reflect the actual performance of the system. The weighting coefficients used are shown in Table 6.

After many iterations of the fault tree analysis program with different SM weighting coefficient values, it is found that, the system operational effectiveness and the system reliability is saturated at a SM weighting coefficient less than or equal 0.5. Thus a weighting coefficient equal to 0.5 was used for the SM. For the final estimated weighting coefficients at operational effectiveness threshold value equal 0 (complete failure), the following results were found:

- the system operational effectiveness over 5 years of satellite lifetime is shown in Fig. 3,
- the reliability of the EPS after 5 years will be equal to 0.976 and,
- the rank of the most critical system blocks and minimal cut sets (which have contribution values more than 5%) and their contribution values are shown in Table 7 and Table 8.

Table 6 EPS Weighting Coefficients

System element	Weighting coefficient
SAS	0.125
BS	0.3

Table 7 Rank of the EPS most critical system blocks and their contribution values

System blocks	Contribution (%)
Each MCC	23.90
Each SAS	5.73

Table 8 Minimal cut sets, which have contribution values more than 5%

Minimal cut set elements	Contribution( %)
The combination of the two MCC	23.90
Each combination consists of two different SA sections	0.41

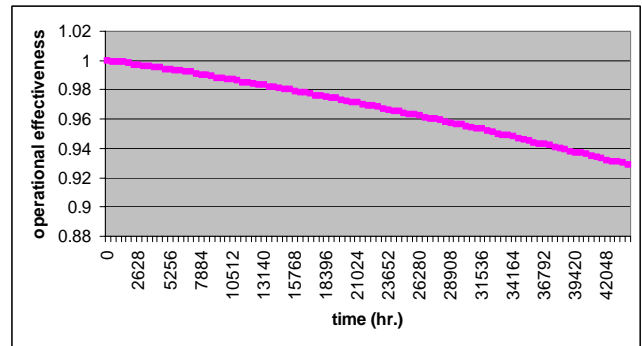

Fig. 3 System operational effectiveness over 5 years of satellite lifetime

The reliability block diagram of the “hot standby” MCM is shown in Fig. 4.

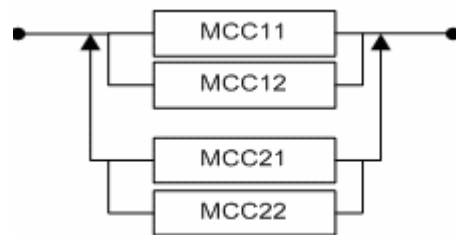

Fig. 4 Parallel “hot standby” MCC Board

The fault tree analysis program which generates the system operational effectiveness over 5 years of satellite lifetime are re-executed again to study and analyze the effect of the new MCM configuration on the EPS operational effectiveness.

The results are shown in Fig. 5.



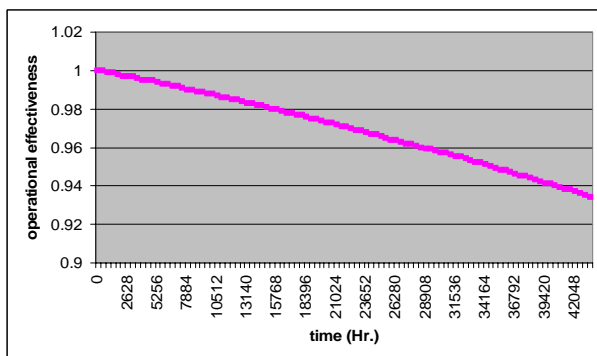

Fig. 5 System operational effectiveness over 5 years of satellite lifetime

The reliability of the EPS after 5 years will be equal to 0.982 and, the rank of the most critical system blocks and minimal cut sets (which have contribution values more than 5%) and their contribution values are shown in Table 9 and Table 10.

Table 9 Rank of the EPS most critical system blocks and their contribution values

System blocks	Contribution (%)
Each SAS	7.53

Table 10 Minimal cut sets, which have contribution values more than 5%

Minimal cut set elements	Contribution(%)
Each combination consists of two different SA sections	0.54

the probability that the system will have operational effectiveness higher than 0.5 and 0.7 after 5 years was calculated and the results were 0.979 and 0.872 respectively. This exemplifies the high reliability of the system performance.

## 5. Conclusions

Applicable LEO Microsatellite EPS configurations are introduced in this paper. In this study, because of reliability, a DET configuration is used in the satellite EPS since it contains a three subsystem solar array (SA), a storage battery (SB) with a power management and control (PMC). Reliability specification and allocation are

introduced and applied in this paper. Conventional and advanced reliability modeling and prediction are also applied for estimation and analysis of EPS reliability. The allocation of EPS reliability is applied by estimation (selection) of the four main parameters for allocation; system intricacy, state of the art technology, performance time and environment. The reliability allocation and modeling results confirm that the EPS reliability meets the requirements.

The satellite EPS operational effectiveness was based on the advanced Monte Carlo Simulation technique. The rank of the most critical blocks and the minimum cut sets are estimated by the help of a developed software program. The results show that the MCC is the most critical block since it contributes by 23.9% and the EPS reliability at EOL is 97.6% as the operational effectiveness is 93%.

A hot redundant was used during operation with a cold redundant (standby) MCC. The results show that the rank of the MCC was reduced to a neglected value < 1% instead of 23.9% and consequently the reliability and operational effectiveness at EOL were 98.2% and 93.5% instead of 97.6% and 93% consequently.

## References

- [1] TERMA A/S Space Division, "Power Management and distribution Systems", www.terma.com.
- [2] D.G. Belov, et.al, "Electric Power Supply for Ocean Satellite", sixth European Space Power Conference, Porto, Portugal, 6-10 May 2002 (ESA SP-502, May 2002).
- [3] Wertz, J. and Larson, W., Eds., Space Mission Analysis and Design. Boston, Kluwer Academic Publishers, 1991.
- [4] Andy Bradford, Luis M Gomes, Prof. Sir Martin Sweeting and Gokhan Yuksel, Cem Ozkaptan, Unsal Orlu, "BILSAT-1: A Low-Cost, AGILE, Earth Observation Microsatellite for TURKEY", 53rd International Astronautical Congress October 2002/Houston, Texas
- [5] Masoum, Mohamed A.S. and Dehbonei, Hooman, "Design, Construction and Testing of a Voltage-based Maximum Power Point Tracker (VMPP) for Small Satellite Power Supply", 13th Annual AIAA/USU Conference on Small Satellites, SSC99-XII-7.
- [6] Flemming Hansen, "Electrical Power System Architecture for Small Satellites", report from Danish Space Research Institute, FH 1999.06.01, <http://www.dsri.dk>.
- [7] Paul E. Panneton and Jason E. Jenkins, "The MSX

Spacecraft Power Subsystem”, Johns Hopkins APL Technical Digest, Volume 17, Number 1 (1996).

- [8] MIL-HDBK-338B, “MILITARY HANDBOOK - ELECTRONIC RELIABILITY DESIGN HANDBOOK”, 1 October 1998.
- [9] Way Kuo, V. rajendra Prasad, Frank A. Taillman and, Ching Lai Hwang, “Optimal Reliability Design: fundamental and applications” hand book, Cambridge university press, 2001
- [10] MIL-HDBK-217A "Reliability Stress and Failure Rate for Electronic Equipment," 1 Dec. (1983).
- [11] MIL-HDBK-217B "Reliability Prediction of Electronic Equipment," 20 Sept. (1974).
- [12] MIL-HDBK-217B Notice 1 7 Sept. (1976).
- [13] MIL-HDBK-217B Notice 2 17 Mar. (1978).
- [14] MIL-HDBK-217C "Reliability Prediction of Electronic Equipment," Apr. 9, (1979).
- [15] MIL-HDBK-217C Notice 1, May 1. (1980).
- [16] MIL-HDBK-217D Notice 1, 13 June (1983).
- [17] MIL-HDBK-217E Oct. 27. (1986).
- [18] MIL-HDBK-217F Dec. 2. (1991).
- [19] MIL-HDBK-217F Notice 1 July (1986).
- [20] ATMEL Corporation Quality & Reliability Handbook 2001-2002, ATMEL Corporation, 2325 Orchard Parkway, San Jose, CA 95131.
- [21] Achintya Haldar and Sankaran Mahadevan, “Reliability Assessment Using Stochastic Finite Element Analysis”, ISBN 0-471-36961-6, John Wiley & sons, 2000.
- [22] European Cooperation For Space Standardization, “fault tree analysis”, CEI/IEC 1025: 1990, 7 September 2001.
- [23] Dr. Michael Stamatelatos, Dr. William Vesely, Dr. Joanne Dugan, Mr. Joseph Fragola, Mr. Joseph Minarick III and, Mr. Jan Railsback, “Fault Tree Handbook with Aerospace Applications”, NASA Office of Safety and Mission Assurance, NASA Headquarters, Washington, DC 20546, Version 1.1, August, 2002.



**Dr. Mohamed Bayoumy A. Zahran** (M. Zahran), was born in Egypt. He received his B.Sc. from Kima High Institute of Technology. He received his M.Sc. in 1993 and Ph.D in 1999 from Cairo University, Faculty of Engineering, Electrical Power and

Machines Dept. He is a Researcher in the Electronics Research Institute, Photovoltaic Cells Dept. His experience is mainly in the field of renewable energy sources, systems design, management and control. Currently, Dr. Zahran is employed by the National Authority for Remote Sensing and Space Science (NARSS) in the Satellite EPS.



**Shady A. Tawfik**, was born in 1979 in Egypt and graduated from the Faculty of Engineering, Electrical Power and Machines Department (Power electronics section) - Cairo University in 2001. Since October 2001, Mr. Tawfik has worked at the National Authority for Remote Sensing and Space Science (NARSS), Cairo Egypt (now as a lead engineer in the Reliability Department). He is engaged in activities related to assuring reliability and effectiveness of satellite systems.



**Gennady Dyakov**, was born in 1976 in the Ukraine and graduated from Zaporizhzh'a Electronics College in 1996. He graduated from the Physical Engineering Department, Dnipropetrovsk State University in 1999. Since 2000, Mr. Dyakov has worked at Yuzhnoye State Design Office “Ukraine” (now as a lead engineer in the Reliability Department). He is engaged in activities related to assuring reliability and safety of space launch systems and spacecraft effectiveness.